

TURN PORT	F	E	D	C	B	A
	0°	90°	180°	270°		
L						

MODEL: **K-301L**

MATERIAL LIST

NO.	PART NAME	MATERIAL
1	BODY	1.4408 / EN1503-1
4	BALL	CF8M / EN1503-2
5	STEM	SS316
9	END CAP	1.4408 / EN1503-1
11	BODY SEAL	PTFE
12	SEAT	PTFE
13	THRUST WASHER	PTFE
14	STEM PACKING	PTFE
16	GLAND NUT	SS304
19	HANDLE	SS304
21	HANDLE COVER	PLASTIC
23	HANDLE WASHER	SS304
24	HANDLE NUT	SS304
28	LOCKING DEVICE	SS304
59	FLOW INDICATOR	SS304

OPTION: MOUNTING HOLE(*)

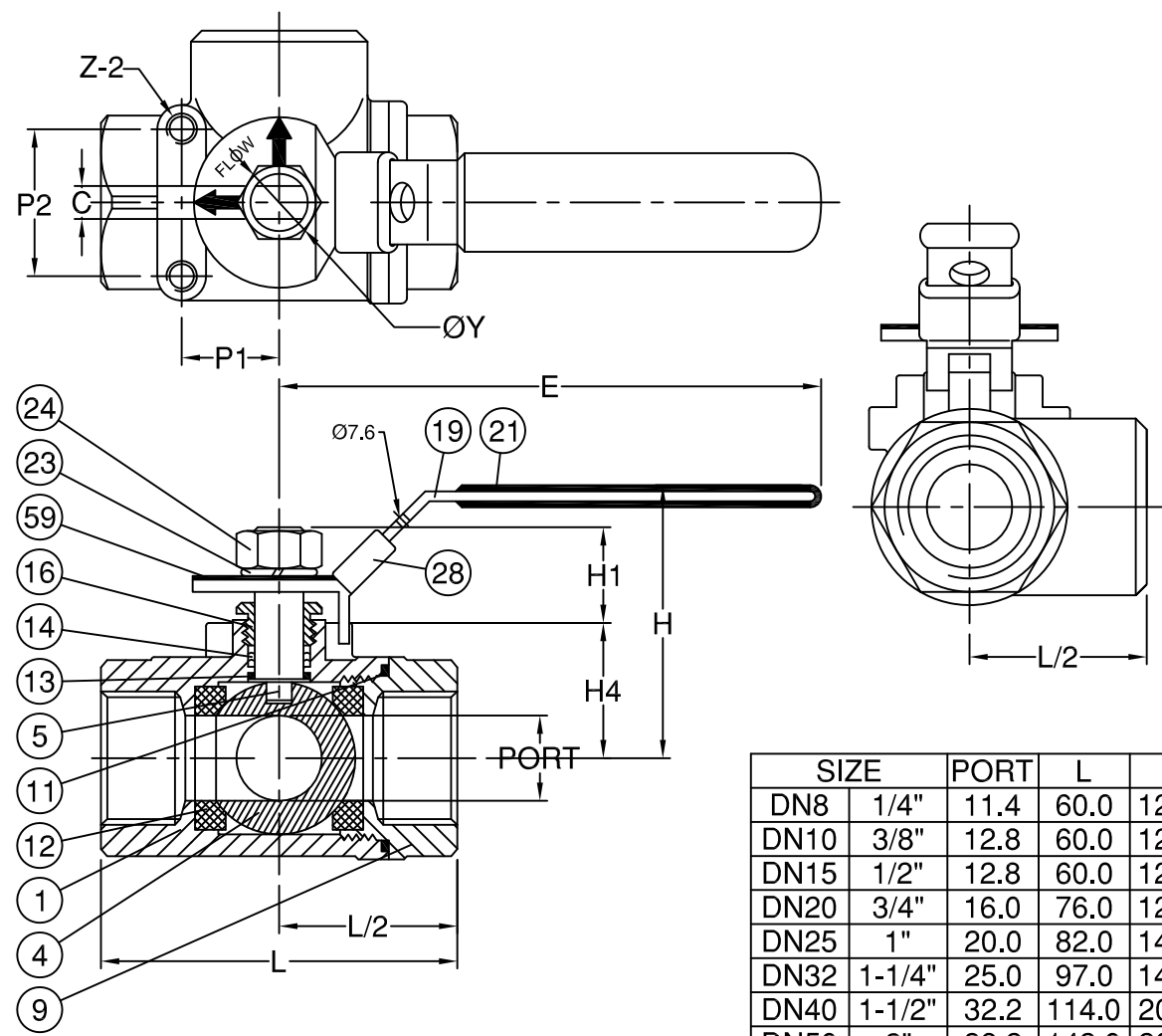

DIMENSIONS

SIZE		PORT	L	E	C	ØY	H	H1	H4	Z*	P1*	P2*
DN8	1/4"	11.4	60.0	125.0	5.0	7/16"	56.0	18.0	24.0	10-24UNC	12.7	28.5
DN10	3/8"	12.8	60.0	125.0	5.0	7/16"	56.0	18.0	24.0	10-24UNC	12.7	28.5
DN15	1/2"	12.8	60.0	125.0	5.0	7/16"	56.0	18.0	24.0	10-24UNC	12.7	28.5
DN20	3/4"	16.0	76.0	125.0	6.5	7/16"	64.0	22.0	32.0	10-24UNC	22.4	35.0
DN25	1"	20.0	82.0	145.0	6.5	7/16"	66.0	22.0	32.0	10-24UNC	22.4	35.0
DN32	1-1/4"	25.0	97.0	145.0	8.0	7/16"	70.0	24.0	42.0	10-24UNC	22.4	35.0
DN40	1-1/2"	32.2	114.0	205.0	8.0	1/2"	83.0	24.0	48.0	1/4"-20UNC	25.4	38.1
DN50	2"	38.2	142.0	205.0	10.0	1/2"	88.0	29.0	53.0	1/4"-20UNC	30.0	38.1

CODE	S-008		DRAWN	JANE	UNIT	mm	BODY	1.4408	PIECE	N/A	SN	N/A
	MODENTIC		CHECKED	CHESTER	SCALE	FREE	SEAT	PTFE	VALVE	BALL	CONNECTION	THREADED END
	INDUSTRIAL CORPORATION		APPROVED	CHESTER	REVISION	02	FIRE SAFE	N/A	BORE	REDUCED	OPERATION	LEVER
			DATE	2015/09/15	NOTE	3-WAY	PORT	L-PORT	TYPE	STANDARD	PRESSURE	PN 63